

CBSE NCERT Solutions for Class 10 Mathematics Chapter 13

Back of Chapter Questions

(Unless stated otherwise, take $\pi = \frac{22}{7}$)

1. 2 cubes each of volume 64 cm^3 are joined end to end. Find the surface area of the resulting cuboid.

Solution:

Volume of cube = 64 cm^3 . Let the side length of the cube be x . Then

$$\Rightarrow x^3 = 64$$

$$\Rightarrow x = 4 \text{ cm}$$

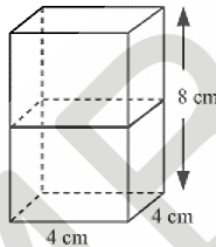

If cubes are joined end to end as shown in the adjacent figure, then the dimensions of resulting cuboid will be 4 cm, 4cm, 8 cm.

We know surface area of cuboid = $2(lb + bh + lh)$ where l is length, b is breadth and h is height of the cuboid. Hence area of the cuboid = $2(4 \times 4 + 4 \times 8 + 4 \times 8)$

$$= 2(16 + 32 + 32)$$

$$= 2 \times 80 = 160 \text{ cm}^2$$

2. A vessel is in the form of a hollow hemisphere mounted by a hollow cylinder. The diameter of the hemisphere is 14 cm and the total height of the vessel is 13 cm. Find the inner surface area of the vessel.

Solution:

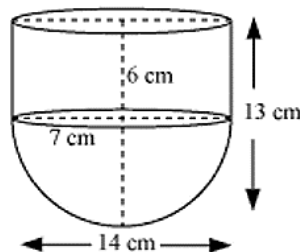

Let the radius of the cylindrical part as well as hemispherical part be r .

Given the diameter of the hemisphere part is 14cm.

$$\Rightarrow 2r = 14$$

$$\Rightarrow r = 7\text{cm}$$

Here we can also say height of hemisphere is 7cm which is radius of the hemisphere.

Now let the height of the cylindrical part be h . Given height of the vessel is 13cm, hence height of the cylindrical part $h = 13 - 7 = 6\text{cm}$.

We know, inner surface area of the hemisphere = $2\pi r^2$ and inner surface area of the cylinder = $2\pi rh$.

Total inner surface area of the vessel = Inner surface area of the hemisphere + Inner surface area of the cylindrical part

$$\text{Total inner surface area of the vessel} = 2\pi r^2 + 2\pi rh.$$

$$\begin{aligned} \text{Total inner surface area of the vessel} &= 2 \times \frac{22}{7} \times 7 \times 7 + 2 \times \frac{22}{7} \times 7 \times 6 \\ &= 44(7 + 6) = 572 \text{ cm}^2. \end{aligned}$$

3. A toy is in the form of a cone of radius 3.5 cm mounted on a hemisphere of same radius. The total height of the toy is 15.5 cm. Find the total surface area of the toy.

Solution:

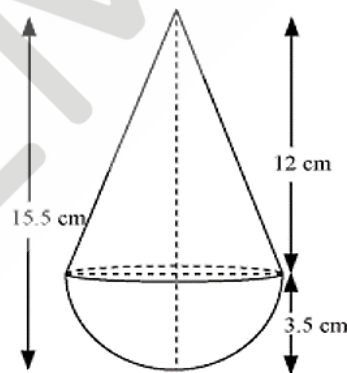

Clearly radius of cone as well hemisphere is same. Let it be $r = 3.5 \text{ cm}$

Height of the hemisphere = radius of hemisphere (r) = 3.5 cm.

Height of toy is given 15.5 cm.

Hence height of cone (h) = $15.5 - 3.5 = 12 \text{ cm}$

Slant height (l) of cone = $\sqrt{r^2 + h^2}$

$$= \sqrt{\left(\frac{7}{2}\right)^2 + (12)^2} = \sqrt{\frac{49}{4} + 144} = \sqrt{\frac{49 + 576}{4}}$$

$$= \sqrt{\frac{625}{4}} = \frac{25}{2} = 12.5 \text{ cm}$$

Total surface area of toy = CSA of cone + CSA of hemisphere

$$\text{Total surface area of toy} = \pi r l + 2\pi r^2$$

$$= \frac{22}{7} \times \frac{7}{2} \times \frac{25}{2} + 2 \times \frac{22}{7} \times \frac{7}{2} \times \frac{7}{2}$$

$$= 137.5 + 77 = 214.5 \text{ cm}^2$$

4. A cubical block of side 7 cm is surmounted by a hemisphere. What is the greatest diameter the hemisphere can have? Find the surface area of the solid.

Solution:

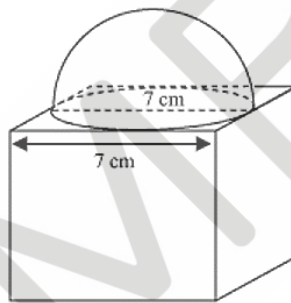

Given a cubical block is surmounted by a hemisphere as in given figure, hence we can say the greatest diameter will be equal to cube's edge = 7 cm.

$$\text{Hence radius (r) of hemisphere} = \frac{7}{2} = 3.5 \text{ cm} \dots \dots \dots (i)$$

Total surface area of solid = surface area of cube + CSA of hemisphere – area of base of hemisphere

$$= 6(\text{edge})^2 + 2\pi r^2 - \pi r^2 = 6(\text{edge})^2 + \pi r^2$$

$$\text{Total surface area of solid} = 6(7)^2 + \frac{22}{7} \times \frac{7}{2} \times \frac{7}{2} = 294 + 38.5 = 332.5 \text{ cm}^2$$

5. A hemispherical depression is cut out from one face of a cubical wooden block such that the diameter l of the hemisphere is equal to the edge of the cube. Determine the surface area of the remaining solid.

Solution:

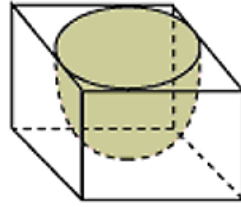

Clearly diameter of hemisphere = edge of cube = l and radius of hemisphere = $\frac{l}{2}$.

Total surface area of solid = surface area of cube + CSA of hemisphere – area of base of hemisphere

$$= 6(\text{edge})^2 + 2\pi r^2 - \pi r^2 = 6(\text{edge})^2 + \pi r^2$$

$$\text{Total surface area of solid} = 6l^2 + \pi \times \left(\frac{l}{2}\right)^2$$

$$= \left(6l^2 + \frac{\pi l^2}{4}\right) \text{unit}^2 = \frac{l^2}{4}(24 + \pi) \text{unit}^2.$$

6. A medicine capsule is in the shape of a cylinder with two hemispheres stuck to each of its ends (see Fig.). The length of the entire capsule is 14 mm and the diameter of the capsule is 5 mm. Find its surface area.

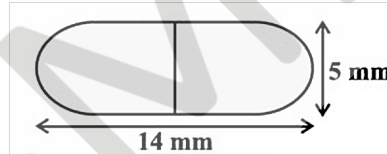

Solution:

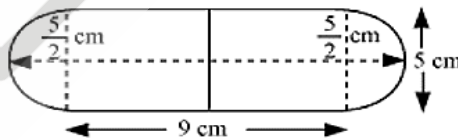

We can observe that in medicine capsule radius of cylinder is equal to radius of hemisphere.

Given diameter of capsule is 5 mm, hence radius of cylinder = radius of hemisphere (r) = $\frac{5}{2}$ mm.

Let the length of the cylinder be h .

Given length of the entire capsule is 14 mm.

Hence length of cylinder (h) = length of the entire capsule – ($2 \times r$)

$$= 14 - 5 = 9 \text{ cm}$$

Surface area of capsule = $2 \times \text{CSA of hemisphere} + \text{CSA of cylinder}$

$$= 2 \times 2\pi r^2 + 2\pi rh$$

$$= 4\pi \left(\frac{5}{2}\right)^2 + 2\pi \left(\frac{5}{2}\right) (9)$$

$$= 25\pi + 45\pi$$

$$= 70\pi \text{ mm}^2$$

$$= 70 \times \frac{22}{7}$$

$$= 220 \text{ mm}^2$$

7. A tent is in the shape of a cylinder surmounted by a conical top. If the height and diameter of the cylindrical part are 2.1 m and 4 m respectively, and the slant height of the top is 2.8 m, find the area of the canvas used for making the tent. Also, find the cost of the canvas of the tent at the rate of ₹ 500 per m^2 . (Note that the base of the tent will not be covered with canvas.)

Solution:

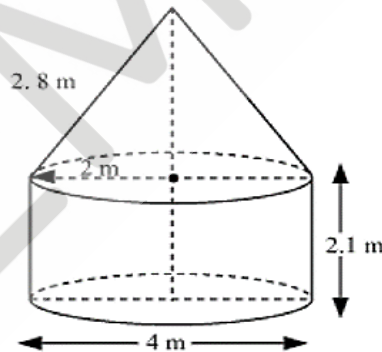

It is given that,

The height (h) of the cylindrical part = 2.1 m

The diameter of the cylindrical part = 4 m

Therefore, the radius of the cylindrical part = 2 m

The slant height (l) of conical part = 2.8 m

The area of canvas used for making the tent = CSA of conical part + CSA of cylindrical part

$$= \pi rl + 2\pi rh$$

$$\begin{aligned}
 &= \pi \times 2 \times 2.8 + 2\pi \times 2 \times 2.1 \\
 &= 2\pi[2.8 + 2 \times 2.1] = 2\pi[2.8 + 4.2] = 2 \times \frac{22}{7} \times 7 \\
 &= 44 \text{ m}^2
 \end{aligned}$$

Cost of 1 m² canvas = ₹ 500

Cost of 44 m² canvas = 44 × 500 = ₹ 22000

So, it will cost ₹ 22000 for making such a tent.

8. From a solid cylinder whose height is 2.4 cm and diameter 1.4 cm, a conical cavity of the same height and same diameter is hollowed out. Find the total surface area of the remaining solid to the nearest cm².

Solution:

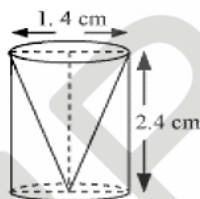

It is given that,

The height (h) of the conical part = height (h) of the cylindrical part = 2.4 cm

The diameter of the cylindrical part = 1.4 cm

Therefore, the radius (r) of the cylindrical part = 0.7 cm

The slant height (l) of conical part = $\sqrt{r^2 + h^2}$

$$= \sqrt{(0.7)^2 + (2.4)^2} = \sqrt{0.49 + 5.76} = \sqrt{6.25} = 2.5 \text{ cm}$$

The total surface area of the remaining solid will be = CSA of cylindrical part + CSA of conical part + area of cylindrical base

$$= 2\pi rh + \pi rl + \pi r^2$$

$$= \left(2 \times \frac{22}{7} \times 0.7 \times 2.4\right) + \left(\frac{22}{7} \times 0.7 \times 2.5\right) + \frac{22}{7} \times 0.7 \times 0.7$$

$$= (4.4 \times 2.4) + (2.2 \times 2.5) + (2.2 \times 0.7)$$

$$= 10.56 + 5.50 + 1.54 = 17.60 \text{ cm}^2$$

It is clear that the total surface area of the remaining solid to the nearest cm² is 18 cm².

9. A wooden article was made by scooping out a hemisphere from each end of a solid cylinder, as shown in figure. If the height of the cylinder is 10 cm, and its base is of radius 3.5 cm, find the total surface area of the article.

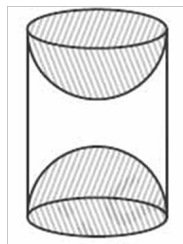

Solution:

From the given diagram it can be clearly observed that radius of hemisphere is same as radius of cylinder.

Given radius of cylindrical part = radius of hemispherical part = $r = 3.5$ cm.

Also, height of the cylinder $h = 10$ cm.

The total surface area of the article = (CSA of cylinder) + (2 × CSA of hemisphere)

$$\begin{aligned}
 &= (2\pi rh) + (2 \times 2\pi r^2) \\
 &= (2\pi \times 3.5 \times 10) + (2 \times 2\pi \times 3.5 \times 3.5) \\
 &= 70\pi + 49\pi \\
 &= 119 \times \frac{22}{7} \\
 &= 17 \times 22 = 374 \text{ cm}^2
 \end{aligned}$$



EXERCISE 13.2

(Unless stated otherwise, take $\pi = \frac{22}{7}$)

1. A solid is in the shape of a cone standing on a hemisphere with both their radii being equal to 1 cm and the height of the cone is equal to its radius. Find the volume of the solid in terms of π .

Solution:

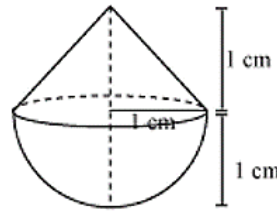

Let the h be the height and r be the radius of the cone. As per given condition

$$h = r = 1 \text{ cm} \dots\dots(i)$$

Also, in the given solid we can easily observe that radius of the cone and radius of hemisphere are equal.

$$\text{Radius of hemisphere} = \text{radius of cone} = r = 1 \text{ cm} \dots\dots(ii)$$

In the hemisphere we can also say that radius as well as height of hemisphere are equal.

$$\text{Radius of hemisphere } (r) = \text{height of hemisphere } (h) = 1 \text{ cm} \dots\dots(iii)$$

Volume of solid = volume of cone + volume of hemisphere

$$= \frac{1}{3} \pi r^2 h + \frac{2}{3} \pi r^3$$

$$= \frac{1}{3} \pi (1)^2 (1) + \frac{2}{3} \pi (1) = \frac{\pi}{3} + \frac{2\pi}{3} = \pi \text{ cm}^3$$

2. Rachel, an engineering student, was asked to make a model shaped like a cylinder with two cones attached at its two ends by using a thin aluminum sheet. The diameter of the model is 3 cm and its length is 12 cm. If each cone has a height of 2 cm, find the volume of air contained in the model that Rachel made. (Assume the outer and inner dimensions of the model to be nearly the same.)

Solution:

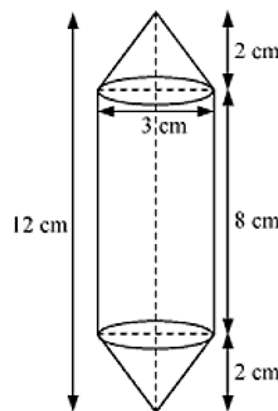

Let h_1 be the height of the cone and h_2 be the height of the cylinder. In the given model radius of cone and cylinder are same, hence let it be r .

Given height of the cone $h_1 = 2$ cm.....(i)

Given height of the model is 12 cm, hence height (h_2) of cylinder
 = 12 - 2 × height of cone
 = 12 - 2 × 2 = 8 cm.....(ii)

Radius of cylinder = Radius of cone= $(r) = \frac{3}{2}$ cm.....(iii)

Volume of air present in the model = volume of cylinder + 2 × volume of cones

$$\begin{aligned}
 &= \pi r^2 h_2 + 2 \times \frac{1}{3} \pi r^2 h_1 \\
 &= \pi \left(\frac{3}{2}\right)^2 (8) + 2 \times \frac{1}{3} \pi \left(\frac{3}{2}\right)^2 (2) \\
 &= \pi \times \frac{9}{4} \times 8 + \frac{2}{3} \pi \times \frac{9}{4} \times 2 \\
 &= 18\pi + 3\pi = 21\pi = 66 \text{ cm}^2
 \end{aligned}$$

3. A *gulab jamun*, contains sugar syrup up to about 30% of its volume. Find approximately how much syrup would be found in 45 *gulab jamuns*, each shaped like a cylinder with two hemispherical ends with length 5 cm and diameter 2.8 cm (see Fig.).



Solution:

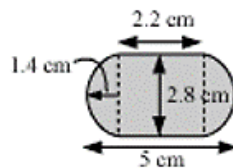

Radius (r) of cylindrical part = radius (r) of hemispherical part = $\frac{2.8}{2} = 1.4$ cm

$$\begin{aligned} \text{Length } (h) \text{ of cylindrical part} &= 5 - 2 \times \text{length of hemispherical part} \\ &= 5 - 2 \times 1.4 = 2.2 \text{ cm} \end{aligned}$$

Volume of one gulab jamun = volume of cylindrical part + 2 × volume of hemispherical part

$$= \pi r^2 h + 2 \times \frac{2}{3} \pi r^3 = \pi r^2 h + \frac{4}{3} \pi r^3$$

$$= \pi \times (1.4)^2 \times 2.2 + \frac{4}{3} \pi (1.4)^3$$

$$= \frac{22}{7} \times 1.4 \times 1.4 \times 2.2 + \frac{4}{3} \times \frac{22}{7} \times 1.4 \times 1.4 \times 1.4$$

$$= 13.55 + 11.50 = 25.05 \text{ cm}^3$$

$$\text{Volume of 45 gulab jamuns} = 45 \times 25.05 = 1,127.25 \text{ cm}^3$$

Volume of sugar syrup = 30% of volume

$$= \frac{30}{100} \times 1,127.279$$

$$\approx 338 \text{ cm}^3$$

4. A pen stand made of wood is in the shape of a cuboid with four conical depressions to hold pens. The dimensions of the cuboid are 15 cm by 10 cm by 3.5 cm. The radius of each of the depressions is 0.5 cm and the depth is 1.4 cm. Find the volume of wood in the entire stand (see figure).

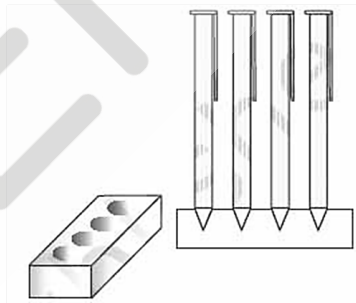

Solution:

It is given that,

The depth (h_1) of each conical depression = 1.4 cm

The radius (r) of each conical depression = 0.5 cm

The length (l) of cuboid = 15 cm

The breadth (b) of cuboid = 10 cm

The height (h) of cuboid = 3.5 cm

$$\begin{aligned}
 \text{Volume of wood in stand} &= \text{volume of cuboid} - (4 \times \text{volume of cones}) \\
 &= (lbh) - (4 \times \frac{1}{3} \pi r^2 h_1) \\
 &= (15 \times 10 \times 3.5) - (4 \times \frac{1}{3} \times \frac{22}{7} \times (\frac{1}{2})^2 \times 1.4) \\
 &= 525 - 1.466 \\
 &= 523.53 \text{ cm}^3
 \end{aligned}$$

5. A vessel is in the form of an inverted cone. Its height is 8 cm and the radius of its top, which is open, is 5 cm. It is filled with water up to the brim. When lead shots, each of which is a sphere of radius 0.5 cm are dropped into the vessel, one-fourth of the water flows out. Find the number of lead shots dropped in the vessel.

Solution:

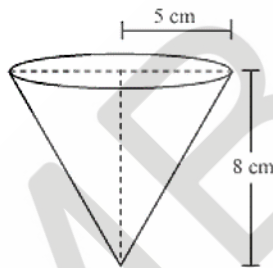

It is given that,

The height (h) of conical vessel = 8 cm

The radius (r_1) of conical vessel = 5 cm

The radius (r_2) of lead shot = 0.5 cm

Let n lead shots were dropped in the vessel

Then the volume of water spilled = volume of dropped lead shots

Which implies, $\frac{1}{4} \times \text{volume of cone} = n \times \frac{4}{3} \pi r_2^3$ (Given: When lead shots are dropped, one-fourth of the water in vessel flows out)

$$\frac{1}{4} \times \left(\frac{1}{3} \pi r_1^2 h \right) = n \times \frac{4}{3} \pi r_2^3$$

$$r_1^2 h = n \times 16 r_2^3$$

$$5^2 \times 8 = n \times 16 \times (0.5)^3$$

$$n = \frac{25 \times 8}{16 \times \left(\frac{1}{2}\right)^3} = 100$$

Therefore, the number of lead shots dropped in the vessel are 100.

6. A solid iron pole consists of a cylinder of height 220 cm and base diameter 24 cm, which is surmounted by another cylinder of height 60 cm and radius 8 cm. Find the mass of the pole, given that 1 cm^3 of iron has approximately 8g mass. (Use $\pi = 3.14$)

Solution:

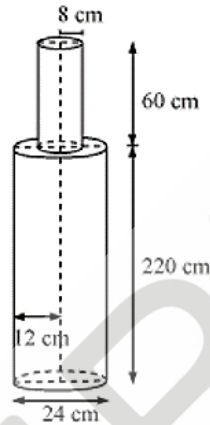

From the figure we have height (h_1) of larger cylinder = 220 cm

It is given that,

The radius (r_1) of larger cylinder = $\frac{24}{2} = 12 \text{ cm}$

The height (h_2) of smaller cylinder = 60 cm

The radius (r_2) of smaller cylinder = 8 cm

The total volume of iron pole = volume of larger cylinder + volume of smaller cylinder

$$\begin{aligned} &= \pi r_1^2 h_1 + \pi r_2^2 h_2 \\ &= \pi (12)^2 \times 220 + \pi (8)^2 \times 60 \\ &= \pi [144 \times 220 + 64 \times 60] \\ &= 35520 \times 3.14 = 1,11,532.8 \text{ cm}^3 \end{aligned}$$

Mass of 1 cm^3 iron = 8 g

Therefore, the mass of 111532.8 cm^3 iron = $111532.8 \times 8 = 892262.4 \text{ g} = 892.26 \text{ kg}$.

7. A solid consisting of a right circular cone of height 120 cm and radius 60 cm standing on a hemisphere of radius 60 cm is placed upright in a right circular

cylinder full of water such that it touches the bottom. Find the volume of water left in the cylinder, if the radius of the cylinder is 60 cm and its height is 180 cm.

Solution:

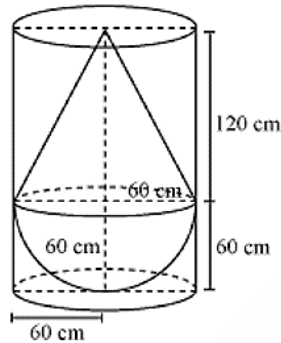

From the figure, the radius (r) of hemispherical part = radius (r) of conical part = 60 cm

It is given that,

The height (h) of right circular cone = 120 cm

The height (h_1) of cylinder = 180 cm

The radius (r) of cylinder = 60 cm

The volume of water left in the cylinder = volume of cylinder – volume of solid

= volume of cylinder – (volume of cone + volume of hemisphere)

$$= \pi r^2 h_1 - \left(\frac{1}{3} \pi r^2 h + \frac{2}{3} \pi r^3 \right)$$

$$= \pi (60)^2 (180) - \left(\frac{1}{3} \pi (60)^2 \times 120 + \frac{2}{3} \pi (60)^3 \right)$$

$$= \pi (60)^2 [(180) - (40 + 40)]$$

$$= \pi (3600) (100) = 360000 \pi \text{ cm}^3 = 1131428.57 \text{ cm}^3 = 1.131 \text{ m}^3 (\text{approx.})$$

8. A spherical glass vessel has a cylindrical neck 8 cm long, 2 cm in diameter; the diameter of the spherical part is 8.5 cm. By measuring the amount of water it holds, a child finds its volume to be 345 cm^3 . Check whether she is correct, taking the above as the inside measurements, and $\pi = 3.14$.

Solution:

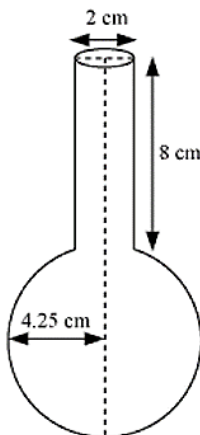

It is given that,

The height (h) of cylindrical part of glass vessel = 8 cm

The radius (r_2) of cylindrical part of glass vessel = $\frac{2}{2} = 1$ cm

The radius (r_1) of spherical part of glass vessel = $\frac{8.5}{2} = 4.25$ cm

Volume of vessel = volume of sphere + volume of cylinder

$$\begin{aligned}
 &= \frac{4}{3} \pi r_1^3 + \pi r_2^2 h \\
 &= \frac{4}{3} \pi \left(\frac{8.5}{2}\right)^3 + \pi (1)^2 (8) \\
 &= 321.39 + 25.12 \\
 &= 346.51 \text{ cm}^3
 \end{aligned}$$

Hence, the volume obtained by the child is not correct. The correct answer is 346.51 cm^3 .



EXERCISE 13.3

(Unless stated otherwise, take $\pi = \frac{22}{7}$)

1. A metallic sphere of radius 4.2 cm is melted and recast into the shape of a cylinder of radius 6 cm. Find the height of the cylinder.

Solution:

Given radius of metallic sphere $r_1 = 4.2$

Also, radius of cylinder $r_2 = 6$

Let height of cylinder be h .

The object formed by recasting the hemisphere will be same in volume.

Hence, volume of sphere = volume of cylinder

$$\begin{aligned}\frac{4}{3}\pi r_1^3 &= \pi h r_2 \\ &= \frac{4}{3}\pi(4.2)^3 = \pi r_2^2 h \\ \frac{4}{3} \times \frac{4.2 \times 4.2 \times 4.2}{36} &= h\end{aligned}$$

$$h = (1.4)^3 = 2.74 \text{ cm}$$

Hence, the height of cylinder so formed will be 2.74 cm.

2. Metallic spheres of radii 6 cm, 8 cm and 10 cm, respectively, are melted to form a single solid sphere. Find the radius of the resulting sphere.

Solution:

It is given that,

The radius (r_1) of 1st metallic sphere = 6 cm

The radius (r_2) of 2nd metallic sphere = 8 cm

The radius (r_3) of 3rd metallic sphere = 10 cm

Let the radius of the resulting sphere be r .

The object formed by recasting these spheres will be same in volume to the sum of volumes of these spheres.

Volume of the three spheres = volume of the resulting sphere

$$\begin{aligned}\Rightarrow \frac{4}{3}\pi[r_1^3 + r_2^3 + r_3^3] &= \frac{4}{3}\pi r^3 \\ \Rightarrow \frac{4}{3}\pi[6^3 + 8^3 + 10^3] &= \frac{4}{3}\pi r^3\end{aligned}$$

$$\Rightarrow r^3 = 216 + 512 + 1000 = 1728 \text{ cm}^3$$

$$\Rightarrow r = 12 \text{ cm}$$

Therefore, the radius of resulting sphere so formed is 12 cm.

3. A 20 m deep well with diameter 7 m is dug and the earth from digging is evenly spread out to form a platform 22 m by 14 m. Find the height of the platform.

Solution:

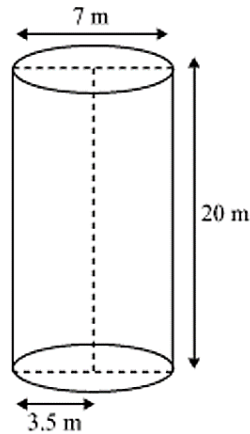

Now, the shape of well will be cylindrical and that of the platform formed is cuboidal.

It is given that,

The depth(h_1) of well = 20 m

The radius (r) of circular end of well = $\frac{7}{2}$ m

Area of platform = length \times breadth = 22×14 m²

Let the height of platform be h .

Volume of soil dug from well will be equal to the volume of soil spread out to form a platform.

Volume of soil from well = volume of soil used to make such platform.

$$\pi \times r^2 \times h_1 = \text{Area of platform} \times \text{Height of platform}$$

$$\Rightarrow \pi \times \left(\frac{7}{2}\right)^2 \times 20 = 22 \times 14 \times h$$

$$\therefore h = \frac{22}{7} \times \frac{49}{4} \times \frac{20}{22 \times 14} = \frac{5}{2} \text{ m}$$

Therefore, the height of the platform formed is 2.5 m.

4. A well of diameter 3 m is dug 14 m deep. The earth taken out of it has been spread evenly all around it in the shape of a circular ring of width 4 m to form an embankment. Find the height of the embankment.

Solution:

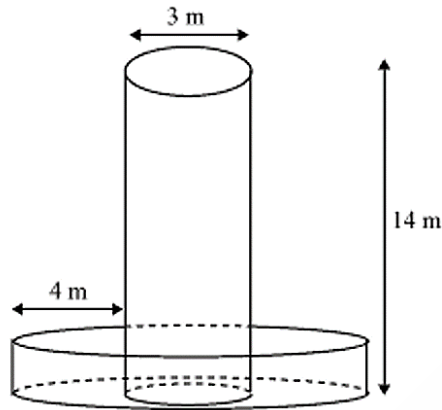

Here, the shape of the well will be cylindrical.

It is given that,

The depth(h_1) of well = 14 m

The radius (r_1) of circular end of well = $\frac{3}{2}$ m

The width of an embankment formed = 4 m

From the figure, embankment will be in a cylindrical shape having outer radius (r_2) as $4 + \frac{3}{2} = \frac{11}{2}$ m and inner radius (r_1) as $\frac{3}{2}$ m

Let height of embankment be h.

Volume of soil dug from well = volume of soil used to form an embankment

$$\Rightarrow \pi \times r_1^2 \times h_1 = \pi \times (r_2^2 - r_1^2) \times h$$

$$\Rightarrow \pi \times \left(\frac{3}{2}\right)^2 \times 14 = \pi \left[\left(\frac{11}{2}\right)^2 - \left(\frac{3}{2}\right)^2\right] \times h$$

$$\Rightarrow \frac{9}{4} \times 14 = \frac{112}{4} \times h$$

$$\Rightarrow h = \frac{9}{8} = 1.125 \text{ m}$$

Therefore, the height of the embankment will be 1.125 m.

5. A container shaped like a right circular cylinder having diameter 12 cm and height 15 cm is full of ice cream. The ice cream is to be filled into cones of height 12 cm and diameter 6 cm, having a hemispherical shape on the top. Find the number of such cones which can be filled with ice cream.

Solution:

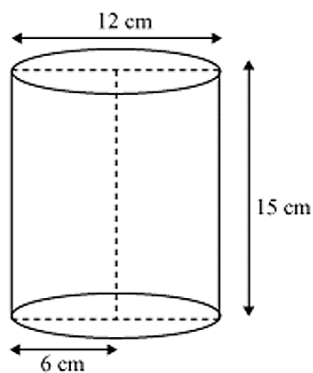

It is given that,

The height (h_1) of cylindrical container = 15 cm

The radius (r_1) of circular end of container = $\frac{12}{2} = 6$ cm

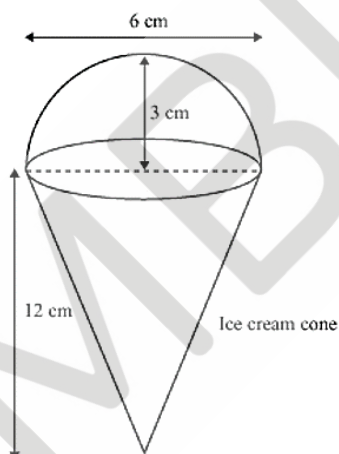

The radius (r_2) of circular end of ice cream cone = $\frac{6}{2} = 3$ cm

The height (h_2) of conical part of ice cream cone = 12 cm

Let n ice cream cones be filled with the ice cream of container.

Volume of ice cream in cylinder = $n \times$ volume of one ice-cream cone

= $n \times$ (volume of conical part + volume of hemisphere)

$$\Rightarrow \pi \times r_1^2 \times h_1 = n \times \left[\frac{1}{3} \pi \times r_2^2 \times h_2 + \frac{2}{3} \pi \times r_2^3 \right]$$

$$\Rightarrow \pi \times 6^2 \times 15 = n \times \left[\frac{1}{3} \pi \times 3^2 \times 12 + \frac{2}{3} \pi \times 3^3 \right]$$

$$\Rightarrow 36 \times 15 = n[36 + 18]$$

$$\Rightarrow n = \frac{36 \times 15}{54}$$

$$\Rightarrow n = 10$$

Therefore, the number of cones, filled with the ice cream is 10.

6. How many silver coins, 1.75 cm in diameter and of thickness 2 mm, must be melted to form a cuboid of dimensions 5.5 cm \times 10 cm \times 3.5 cm?

Solution:

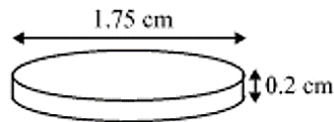

We know that coins are cylindrical in shape.

It is given that,

The Height (h_1) of cylindrical silver coins = 2 mm = 0.2 cm (Since, here thickness = height)

The radius (r) of circular end of silver coins = $\frac{1.75}{2} = 0.875$ cm

Let n coins be melted to form the required cuboid of dimensions 5.5 cm \times 10 cm \times 3.5 cm.

Volume of n cylindrical silver coins = volume of cuboid

$$\Rightarrow n \times \pi \times r^2 \times h_1 = l \times b \times h$$

$$\Rightarrow n \times \pi \times (0.875)^2 \times 0.2 = 5.5 \times 10 \times 3.5$$

$$\Rightarrow n = \frac{5.5 \times 10 \times 3.5 \times 7}{(0.875)^2 \times 0.2 \times 22} = \frac{1347.5}{3.36875} = 400$$

Therefore, the number of silver coins melted to form such a cuboid is 400.

7. A cylindrical bucket, 32 cm high and with radius of base 18 cm, is filled with sand. This bucket is emptied on the ground and a conical heap of sand is formed. If the height of the conical heap is 24 cm, find the radius and slant height of the heap.

Solution:

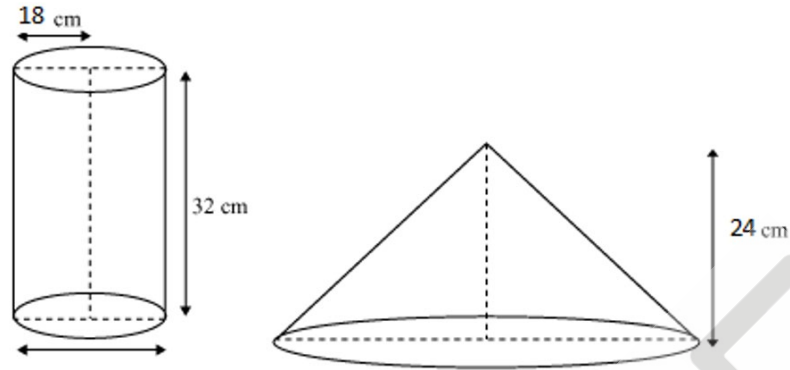

It is given that,

The height (h_1) of cylindrical bucket = 32 cm

The radius (r_1) of circular end of bucket = 18 cm

The height (h_2) of the conical heap = 24 cm

Let radius of circular end of conical heap be r_2 .

Volume of sand in the cylindrical bucket will be equal to the volume of sand in conical heap

Volume of sand in the cylindrical bucket = volume of sand in conical heap

$$\pi \times r_1^2 \times h_1 = \frac{1}{3} \pi \times r_2^2 \times h_2$$

$$\pi \times 18^2 \times 32 = \frac{1}{3} \pi \times r_2^2 \times 24$$

$$r_2 = 18 \times 2 = 36 \text{ cm}$$

$$\text{Slant height} = \sqrt{36^2 + 24^2} = \sqrt{12^2 \times (3^2 + 2^2)} = 12\sqrt{13} \text{ cm}$$

Therefore, the radius and slant height of the heap are 36 cm and $12\sqrt{13}$ cm respectively.

8. Water in a canal, 6 m wide and 1.5 m deep, is flowing with a speed of 10 km/h. How much area will it irrigate in 30 minutes, if 8 cm of standing water is needed?

Solution:

Consider an area of cross section of canal with width and depth.

$$\text{Area of cross section of canal} = 6 \times 1.5 = 9 \text{ m}^2$$

$$\text{Speed of water} = 10 \frac{\text{km}}{\text{h}} = \frac{10000}{60} \text{ m/min}$$

Since canal is in shape of cuboid,

The length of the cuboid due to water flow from canal in 1 minute = $\frac{10000}{60}$ m

So, the volume of water that flows in 1 minute from canal = Area of cross section \times length

$$= 9 \times \frac{10000}{60} = 1500 \text{ m}^3$$

Therefore, the volume of water that flows in 30 minutes from canal = $30 \times 1500 = 45000 \text{ m}^3$

Let the irrigated area be A .

Given: Height = 8 cm = $\frac{8}{100}$ m

The volume of water irrigated in the required area = The volume of water flowed in 30 minutes from canal.

$$\frac{A \times 8}{100} = 45000$$

$$A = 562500 \text{ m}^2$$

We know that 1 hectare = 10000 m^2 .

So, area irrigated in 30 minutes is 562500 m^2 or 56.25 hectares.

9. A farmer connects a pipe of internal diameter 20 cm from a canal into a cylindrical tank in her field, which is 10 m in diameter and 2 m deep. If water flows through the pipe at the rate of 3 km/h, in how much time will the tank be filled?

Solution:

Consider an area of cross section of pipe

Radius (r_1) of circular end pipe = $\frac{20}{200} = 0.1$ m

Area of cross section = $\pi \times r_1^2 = \pi \times (0.1)^2 = 0.01\pi \text{ m}^2$

Speed of water = $3 \frac{\text{km}}{\text{h}} = \frac{3000}{60} = 50$ m/min

(Since pipe is in form of cylinder. Volume = Area of cross section \times length along the pipe)

Volume of water that flows in 1 minute from pipe = $50 \times 0.01 \pi = 0.5\pi \text{ m}^3$

Volume of water that flows in t minutes from pipe = $t \times 0.5\pi \text{ m}^3$

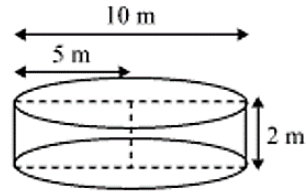

Radius (r_2) of circular end of cylindrical tank = $\frac{10}{2} = 5$ m

Depth (h_2) of cylindrical tank = 2 m

Let in t minutes the tank will be filled completely.

Volume of water filled in tank in t minutes is equal to that volume of water flowed in t minutes from pipe.

Volume of water that flows in t minutes from pipe = volume of water in tank

$$\Rightarrow t \times 0.5 \pi = \pi \times (r_2)^2 \times h_2$$

$$\Rightarrow t \times 0.5 = 5^2 \times 2$$

Hence, the cylindrical tank will be filled in 100 minutes.



EXERCISE 13.4

(Unless stated otherwise, take $\pi = \frac{22}{7}$)

1. A drinking glass is in the shape of a frustum of a cone of height 14 cm. The diameters of its two circular ends are 4 cm and 2 cm. Find the capacity of the glass.

Solution:

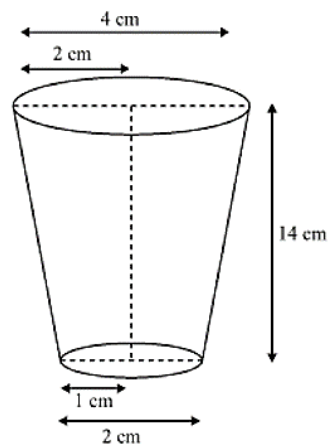

It is given that,

$$\text{The radius } (r_1) \text{ of upper base of glass} = \frac{4}{2} = 2 \text{ cm}$$

$$\text{The radius } (r_2) \text{ of lower base of glass} = \frac{2}{2} = 1 \text{ cm}$$

Capacity of glass = volume of frustum of cone

$$= \frac{1}{3} \pi h (r_1^2 + r_2^2 + r_1 r_2)$$

$$= \frac{1}{3} \pi h [(2)^2 + (1)^2 + (2)(1)]$$

$$= \frac{308}{3} = 102\frac{2}{3} \text{ cm}^3.$$

Therefore, the capacity of the glass is $102\frac{2}{3} \text{ cm}^3$

2. The slant height of a frustum of a cone is 4 cm and the perimeters (circumference) of its circular ends are 18 cm and 6 cm. Find the curved surface area of the frustum.

Solution:

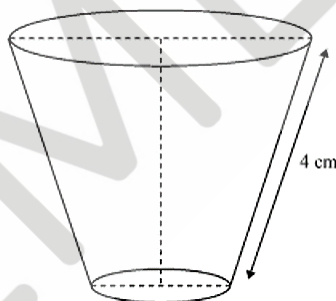

It is given that,

$$\text{Perimeter of upper circular end of frustum} = 18$$

$$\Rightarrow 2\pi r_1 = 18$$

$$\Rightarrow r_1 = \frac{9}{\pi}$$

$$\text{Perimeter of lower end of frustum} = 6 \text{ cm.}$$

$$\Rightarrow 2\pi r_2 = 6$$

$$\Rightarrow r_2 = \frac{3}{\pi}$$

$$\text{Slant height } (l) \text{ of frustum} = 4$$

$$\text{CSA of frustum} = \pi(r_1 + r_2)l$$

$$\begin{aligned}
 &= \pi \left(\frac{9}{\pi} + \frac{3}{\pi} \right) 4 \\
 &= 12 \times 4 \\
 &= 48 \text{ cm}^2
 \end{aligned}$$

Therefore, the curved surface area of the frustum is 48 cm^2 .

3. A *fez*, the cap used by the Turks, is shaped like the frustum of a cone (see figure). If its radius on the open side is 10 cm, radius at the upper base is 4 cm and its slant height is 15 cm, find the area of material used for making it.

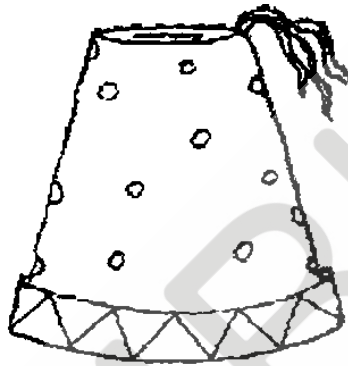

Solution:

It is given that,

The radius (r_2) at upper circular end = 4 cm

The radius (r_1) at lower circular end = 10 cm

Slant height (l) of frustum = 15 cm

Area of material used for making the *fez* = CSA of frustum + area of upper circular end

$$\begin{aligned}
 &= \pi(r_1 + r_2)l + \pi r_2^2 \\
 &= \pi(10 + 4)15 + \pi(4)^2 \\
 &= 210\pi + 16\pi = \frac{226 \times 22}{7} \\
 &= 710 \frac{2}{7} \text{ cm}^2
 \end{aligned}$$

Hence, the area of material used for making it is $710 \frac{2}{7} \text{ cm}^2$.

4. A container, opened from the top and made up of a metal sheet, is in the form of a frustum of a cone of height 16 cm with radii of its lower and upper ends as 8 cm and 20 cm, respectively. Find the cost of the milk which can completely fill the

container, at the rate of ₹ 20 per litre. Also find the cost of metal sheet used to make the container, if it costs ₹ 8 per 100 cm². (Take $\pi = 3.14$)

Solution:

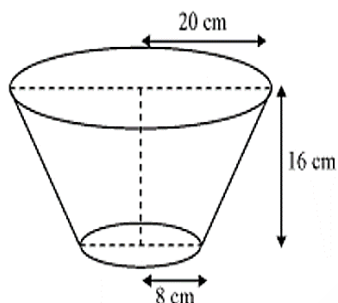

It is given that,

The radius (r_1) of upper end of container = 20 cm

The radius (r_2) of lower end of container = 8 cm

The height (h) of container = 16 cm

Slant height (l) of frustum = $\sqrt{(r_1 - r_2)^2 + h^2}$

$$= \sqrt{(20 - 8)^2 + (16)^2}$$

$$= \sqrt{(12)^2 + (16)^2} = \sqrt{144 + 256}$$

$$= 20 \text{ cm}$$

Capacity of container = volume of frustum

$$= \frac{1}{3} \pi h (r_1^2 + r_2^2 + r_1 r_2)$$

$$= \frac{1}{3} \times 3.14 \times 16 \times [(20)^2 + (8)^2 + (20)(8)]$$

$$= \frac{1}{3} \times 3.14 \times 16 \times 624 = 16.74 \times 624 = 10449.92 \text{ cm}^3$$

$$= 10.45 \text{ litre} \quad (\text{Since } 1 \text{ litre} = 1000 \text{ cm}^3)$$

Cost of 1 litre milk = ₹ 20

Cost of 10.45 litre milk = $10.45 \times 20 = ₹ 209$

Area of metal sheet used to make the container = CSA of frustum + area of lower circular end

$$= \pi(r_1 + r_2)l + \pi r_2^2$$

$$= \pi(20 + 8)20 + \pi(8)^2$$

$$= 560 \pi + 64 \pi = 624 \pi \text{ cm}^2$$

$$\text{Cost of } 100 \text{ cm}^2 \text{ metal sheet} = ₹ 8$$

$$\text{Cost of } 624 \pi \text{ cm}^2 \text{ metal sheet} = \frac{624 \times 3.14 \times 8}{100} = ₹ 156.75$$

Therefore, the cost of the milk which can completely fill the container is ₹ 209 and the cost of metal sheet used to make the container is ₹ 156.75.

5. A metallic right circular cone 20 cm high and whose vertical angle is 60° is cut into two parts at the middle of its height by a plane parallel to its base. If the frustum so obtained be drawn into a wire of diameter $\frac{1}{16}$ cm, find the length of the wire.

Solution:

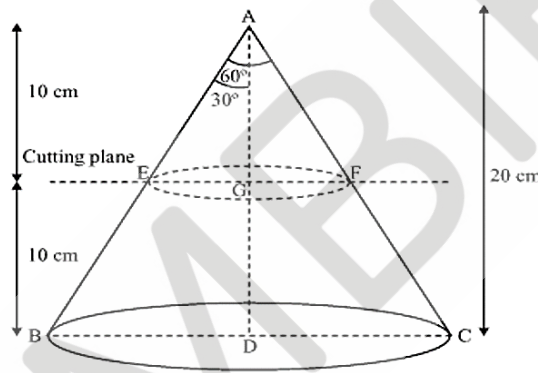

In $\triangle AEG$

$$\frac{EG}{AG} = \tan 30^\circ$$

$$EG = \frac{10}{\sqrt{3}} \text{ cm} = \frac{10\sqrt{3}}{3}$$

In $\triangle ABD$

$$\frac{BD}{AD} = \tan 30^\circ$$

$$BD = \frac{20}{\sqrt{3}} = \frac{20\sqrt{3}}{3} \text{ cm}$$

$$\text{Radius } (r_1) \text{ of upper end of frustum} = \frac{10\sqrt{3}}{3} \text{ cm}$$

$$\text{Radius } (r_2) \text{ of lower end of frustum} = \frac{20\sqrt{3}}{3} \text{ cm}$$

$$\text{Height } (h) \text{ of container} = 10 \text{ cm}$$

$$\begin{aligned}
 \text{Volume of frustum} &= \frac{1}{3}\pi h(r_1^2 + r_2^2 + r_1r_2) \\
 &= \frac{1}{3} \times \pi \times 10 \left[\left(\frac{10\sqrt{3}}{3}\right)^2 + \left(\frac{20\sqrt{3}}{3}\right)^2 + \frac{(10\sqrt{3})(20\sqrt{3})}{3 \times 3} \right] \\
 &= \frac{10}{3} \pi \left[\frac{100}{3} + \frac{400}{3} + \frac{200}{3} \right] \\
 &= \frac{10}{3} \times \frac{22}{7} \times \frac{700}{3} = \frac{22000}{9} \text{ cm}^3
 \end{aligned}$$

$$\text{Radius (r) of wire} = \frac{1}{16} \times \frac{1}{2} = \frac{1}{32} \text{ cm}$$

Let length of wire be l .

$$\text{Volume of wire} = \text{Area of cross section} \times \text{length} = (\pi r^2)(l)$$

$$= \pi \left(\frac{1}{32}\right)^2 \times l$$

Since volume of frustum = volume of wire

$$\frac{22000}{9} = \pi \left(\frac{1}{32}\right)^2 \times l$$

$$\frac{22000}{9} \times 1024 \times \frac{7}{22} = l$$

$$l = 796444.44 \text{ cm}$$

$$l = 7964.4 \text{ m}$$

Hence, the length of the wire is 7964.4 m



EXERCISE 13.5 (Optional)*

1. A copper wire, 3 mm in diameter, is wound about a cylinder whose length is 12 cm, and diameter 10 cm, so as to cover the curved surface of the cylinder. Find the length and mass of the wire, assuming the density of copper to be 8.88 g per cm^3 .

Solution:

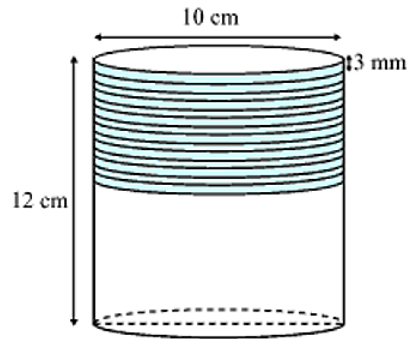

1 round of wire will cover 3 mm height of cylinder.

$$\begin{aligned} \text{Number of rounds} &= \frac{\text{Height of cylinder}}{\text{Diameter of wire}} \\ &= \frac{12}{0.3} = 40 \text{ rounds} \end{aligned}$$

Length of wire required in 1 round = circumference of base of cylinder

$$= 2\pi r = 2\pi \times 5 = 10\pi$$

$$\text{length of wire in 40 rounds} = 40 \times 10\pi$$

$$\text{Length of wire in } 40 \times 10\pi$$

$$= \frac{400 \times 22}{7} = \frac{8800}{7} = 1257.14 \text{ cm} = 12.57 \text{ m}$$

$$\text{Radius of wire} = \frac{0.3}{2} = 0.15 \text{ cm}$$

$$\text{Volume of wire} = \text{Area of cross section of wire} \times \text{length of wire} = \pi(0.15)^2 \times 1257.14$$

$$= 88.89 \text{ cm}^3$$

$$\text{Mass} = \text{Volume} \times \text{Density} = 88.89 \times 8.88 = 789.41 \text{ gm}$$

2. A right triangle, whose sides are 3 cm and 4 cm (other than hypotenuse) is made to revolve about its hypotenuse. Find the volume and surface area of the double cone so formed. (Choose value of π as found appropriate.)

Solution:

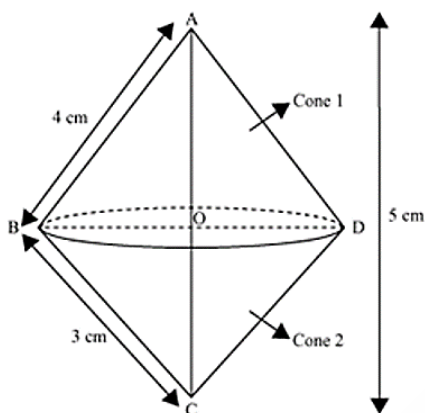

Double cone so formed by revolving this right angle triangle ABC about its hypotenuse is shown in figure.

$$\text{Hypotenuse } AC = \sqrt{3^2 + 4^2} = \sqrt{25} = 5 \text{ cm}$$

$$\text{Area of } \triangle ABC = \frac{1}{2} \times AB \times BC$$

$$\frac{1}{2} \times AC \times OB = \frac{1}{2} \times 4 \times 3$$

$$\frac{1}{2} \times 5 \times OB = \frac{12}{2}$$

$$OB = \frac{12}{5} = 2.4 \text{ cm}$$

Volume of double = volume of cone 1 + volume of cone 2

$$= \frac{1}{3} \pi r^2 h_1 + \frac{1}{3} \pi r^2 h_2$$

$$= \frac{1}{3} \pi r^2 (h_1 + h_2) = \frac{1}{3} \pi r^2 (OA + OC)$$

$$= \frac{1}{3} \times \frac{22}{7} \times (2.4)^2 (5)$$

$$= 30.14 \text{ cm}^3$$

Surface area of double cone = surface area cone 1 + surface area of

$$= \pi r l_1 + \pi r l_2$$

$$= \pi r [4 + 3] = \frac{22}{7} \times 2.4 \times 7$$

$$= 52.8 \text{ cm}^2$$

3. A cistern, internally measuring $150 \text{ cm} \times 120 \text{ cm} \times 110 \text{ cm}$, has 129600 cm^3 of water in it. Porous bricks are placed in the water until the cistern is full to the

brim. Each brick absorbs one-seventeenth of its own volume of water. How many bricks can be put in without overflowing the water, each brick being $22.5 \text{ cm} \times 7.5 \text{ cm} \times 6.5 \text{ cm}$?

Solution:

$$\text{Volume of cistern} = 150 \times 120 \times 110 = 1980000 \text{ cm}^3$$

$$\text{Volume to be filled in cistern} = 1980000 - 129600 = 1850400 \text{ cm}^3$$

Let n numbers of porous bricks were placed in cistern.

$$\text{So volume of } n \text{ bricks} = n \times 22.5 \times 7.5 \times 6.5 = 1096.875 n$$

As each brick absorbs one seventeenth of its volume, so volume absorbed by these bricks $= \frac{1}{17}(1096.875)n$

$$1850400 + \frac{n}{17}(1096.875) = (1096.875)n$$

$$\Rightarrow 1850400 = \frac{16n}{17}(1096.875)$$

$$\Rightarrow n = 1792.41$$

So, 1792 bricks were placed in the cistern.

4. In one fortnight of a given month, there was a rainfall of 10 cm in a river valley. If the area of the valley is 7280 km^2 , show that the total rainfall was approximately equivalent to the addition to the normal water of three rivers each 1072 km long, 75 m wide and 3 m deep.

Solution:

$$\text{Area of the valley} = 97280 \text{ km}^2$$

$$\text{Height of rainfall in valley} = 10 \text{ cm} = 10 \times 10^{-6} = 10^{-5} \text{ km}$$

$$\text{Now, volume of rain water in valley} = \text{area of the valley} \times \text{height of rainfall into valley} = 97280 \times 10^{-5} \text{ km}^3 = 0.9728 \text{ km}^3$$

$$\text{Volume of water in valley } 0.9728 \text{ km}^3 \text{ in 14 days [according to question]}$$

$$\text{So, volume of water in valley in 1 day} = 0.9728/14 \approx 0.7 \text{ km}^3$$

$$\text{Now, volume of each river} = \text{length} \times \text{Breadth} \times \text{height}$$

$$= 1072 \text{ km} \times 75 \text{ m} \times 3 \text{ m}$$

$$= 1072 \times 75 \times 10^{-3} \times 3 \times 10^{-3} \text{ km}^3$$

$$= 0.2412 \text{ km}^3$$

$$\text{So, volume of 3 rivers} = 3 \times \text{volume of each river}$$

$$= 3 \times 0.2412 \text{ km}^3$$

$$= 0.7236 \text{ km}^3 \approx 0.7 \text{ km}^3$$

Here it is clear that approximately volume of water in valley {means volume of rainfall water} = volume of water in 3 rivers.

5. An oil funnel made of tin sheet consists of a 10 cm long cylindrical portion attached to a frustum of a cone. If the total height is 22 cm, diameter of the cylindrical portion is 8 cm and the diameter of the top of the funnel is 18 cm, find the area of the tin sheet required to make the funnel (see Fig.).

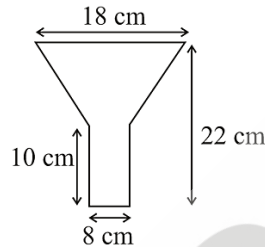

Solution:

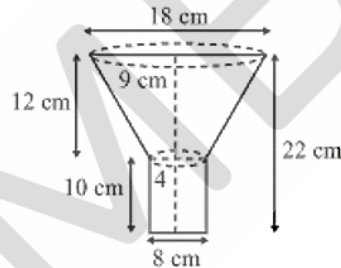

Radius (r_1) of upper circular end of frustum part = $\frac{18}{2} = 9$ cm

Radius (r_2) of lower circular end of frustum part = radius of circular end of cylindrical part = $\frac{8}{2} = 4$ cm

Height (h_1) of frustum part = $22 - 10 = 12$ cm

Height (h_2) of cylindrical part = 10 cm slant height (l) of frustum part

$$= \sqrt{(r_1 - r_2)^2 + h^2} = \sqrt{(9 - 4)^2 + (12)^2} = 13 \text{ cm}$$

Area of tin sheet required = CSA of frustum part + CSA of cylindrical part

$$= \pi(r_1 + r_2)l + 2\pi r_2 h_2$$

$$= \frac{22}{7} \times (9 + 4) \times 13 + 2 \times \frac{22}{7} \times 4 \times 10$$

$$= \frac{22}{7} [169 + 80] = \frac{22 \times 249}{7}$$

$$= 782 \frac{4}{7} \text{ cm}^2$$

6. Derive the formula for the curved surface area and total surface area of the frustum of a cone, given to you in Section 13.5, using the symbols as explained.

Solution:

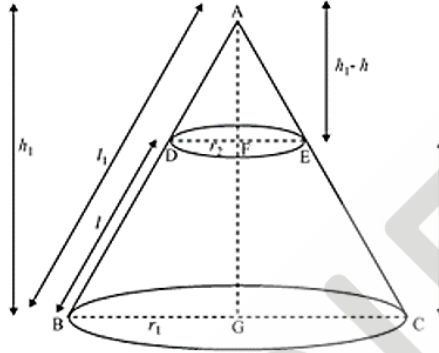

Let ABC be a cone. A frustum DECB is cut by a plane parallel to its base.

In $\triangle ABG$ and $\triangle ADF$

As $\triangle ABG \sim \triangle ADF$

$$\frac{DF}{BG} = \frac{AF}{AG} = \frac{AD}{AB}$$

$$\frac{r_2}{r_1} = \frac{h_1 - h}{h_1} = \frac{l_1 - l}{l_1}$$

$$\frac{r_2}{r_1} = 1 - \frac{h}{h_1} = 1 - \frac{l}{l_1}$$

$$\frac{1 - l}{l_1} = \frac{r_2}{r_1}$$

$$\frac{l}{l_1} = 1 - \frac{r_2}{r_1} = \frac{r_1 - r_2}{r_1}$$

$$\frac{l_1}{l} = \frac{r_1}{r_1 - r_2}$$

CSA of frustum DECB = CSA of cone ABC – CSA cone ADE

$$= \pi r_1 l_1 - \pi r_2 (l_1 - l)$$

$$= \pi r_1 \left(\frac{l r_1}{r_1 - r_2} \right) - \pi r_2 \left[\frac{r_1 l}{r_1 - r_2} - l \right]$$

$$= \frac{\pi r_1^2 l}{r_1 - r_2} - \pi r_2 \left(\frac{r_1 l - r_2 l}{r_1 - r_2} \right)$$

$$= \frac{\pi r_1^2 l}{r_1 - r_2} - \frac{\pi r_2^2 l}{r_1 - r_2}$$

$$= \pi l \left[\frac{r_1^2 - r_2^2}{r_1 - r_2} \right]$$

CSA of frustum = $\pi(r_1 + r_2)l$

Total surface are of frustum = CSA of frustum + area of upper circular end + area of lower circular end

$$= \pi(r_1 + r_2)l + \pi r_2^2 + \pi r_1^2$$

$$= \pi[(r_1 + r_2)l + r_1^2 + r_2^2]$$

7. Derive the formula for the volume of the frustum of a cone, given to you in Section 13.5, using the symbols as explained.

Solution:

We have,

[Volume of the frustum RPQS]

= [Volume of right circular cone OPQ] - [Volume of right circular cone ORS]

$$= \frac{1}{3} \pi r_1^2 h_1 - \frac{1}{3} \pi r_2^2 h_2$$

$$= \frac{1}{3} \pi [r_1^2 h_1 - r_2^2 h_2] \dots\dots\dots (1)$$

Since $\Delta OC_1Q \sim \Delta OC_2S$

$$\therefore \frac{OQ}{OS} = \frac{QC_1}{SC_2} = \frac{OC_1}{OC_2}$$

$$\Rightarrow \frac{h_1}{h_2} = \frac{r_1}{r_2} = \frac{h_1}{h_2} \Rightarrow h_1 = \left(\frac{r_1}{r_2} \times h_2 \right) \dots\dots\dots (2)$$

$$\Rightarrow \frac{r_1}{r_2} = \frac{h + h_2}{h_2}$$

$$\Rightarrow \frac{r_1}{r_2} = \frac{h_1}{h_2} + 1$$

$$\Rightarrow \frac{h}{h_2} = \frac{r_1}{r_2} - 1 \Rightarrow h = \left[\frac{r_1}{r_2} - 1 \right] \times h_2$$

$$\Rightarrow h = (r_1 - r_2) \frac{h_2}{r_2}$$

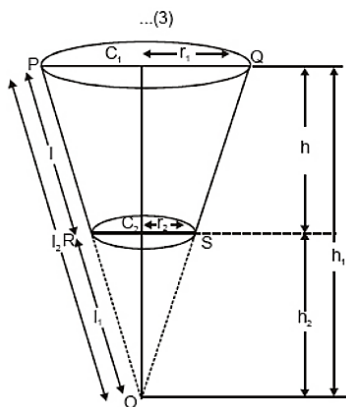

From (1) and (2), we have

$$\begin{aligned}
 \{\text{volume of the frustum RPQS}\} &= \frac{1}{3} \pi \left[r_1^2 \times \frac{r_1}{r_2} h_2 - r_2^2 h_2 \right] \\
 &= \frac{1}{3} \pi \left[\frac{r_1^3}{r_2} - r_2^2 \right] h_2 \\
 &= \frac{1}{3} \pi [r_1^3 - r_2^3] \frac{h_2}{r_2} \\
 &= \frac{1}{3} \pi (r_1^2 + r_2^2 + r_1 r_2) \left[(r_1 - r_2) \frac{h_2}{r_2} \right] \\
 &= \frac{1}{3} \pi (r_1^2 + r_2^2 + r_1 r_2) h
 \end{aligned}$$

◆ ◆ ◆